

Specifications and equipment are subject to change without any notice or obligation on the part of the manufacturer.  
The colour of products in this brochure may differ from the actual products due to the colour of the printing ink used.  
January 2015  
©2015 NIKON VISION CO., LTD.



**WARNING**

Never look at the sun directly through optical equipment. It may cause damage to or loss of eyesight.



**NIKON VISION CO., LTD.**

Nikon Futaba Bldg., 3-25, Futaba 1-chome,  
Shinagawa-ku, Tokyo 142-0043, Japan  
Tel: +81-3-3788-7697 Fax: +81-3-3788-7698

[www.nikon.com/sportoptics](http://www.nikon.com/sportoptics)

En

Printed in Japan Code No. 3CE-BPJH-6 (1501-13) V



# COOLSHOT

*The Golfer's Laser Rangefinders*

*GAIN CONFIDENCE*

*Master distance and develop a golfing sense with COOLSHOT.*

*By knowing your distance and the true shot distance,  
you can confidently choose the right club.*

*COOLSHOT is built for golfers. It enables you to be at your best  
on the fairway and on the green.*

*If strategic golf is your game,  
play with confidence—play with COOLSHOT.*

## COOLSHOT

*The Golfer's Laser Rangefinders*



COOLSHOT 40i NEW

COOLSHOT 40 NEW

COOLSHOT 20

# TECHNOLOGY

COOLSHOT's distance-measurement performance is fully optimized to ensure your target is secured with speed and superior accuracy. Without compromise, Nikon specifically designs COOLSHOT's functions and usability for golfers. You can focus on your game with stress-free operation.



## Golf mode with ID Technology: Slope adjusted distance



With ID Technology, the Golf mode displays the slope adjusted distance (horizontal distance ± height), enabling you to select the right club for uphill or downhill shots.

※ Models that offer ID Technology: COOLSHOT 40i/LASER 1000A S

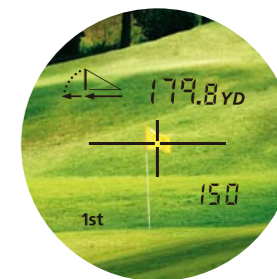

Viewfinder display example (for uphill): The upper figure shows the "slope adjusted distance" while the one below indicates the "actual distance."

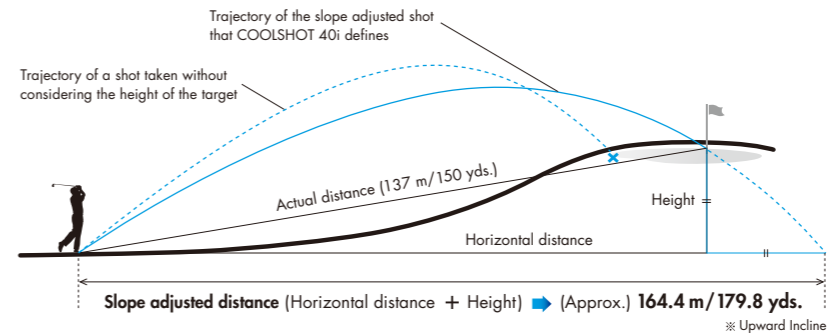

For an uphill shot with an actual distance of 150 yards the Golf mode displays the slope adjusted distance (179.8 yds.), which is the sum of the horizontal distance (146.4 yds.) and the height (33.4 yds.). You can thus select the right club for even both up and down hill shots.

### Display mode cycle

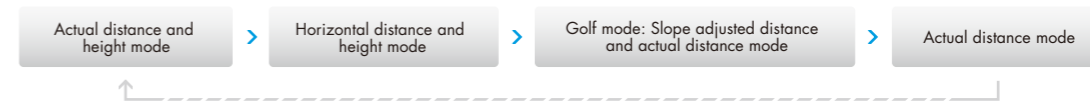

### Nikon's system design: Minimised measurement errors

The Nikon Laser Rangefinder's system design meets the exacting requirements of professional golfers. Nikon engineers determined the system design through repeated simulations that enable invisible laser rays to be precisely picked up by a sensing unit. High-quality integrated circuits and sophisticated software not only provide outstanding measurement performance, but also quick response.

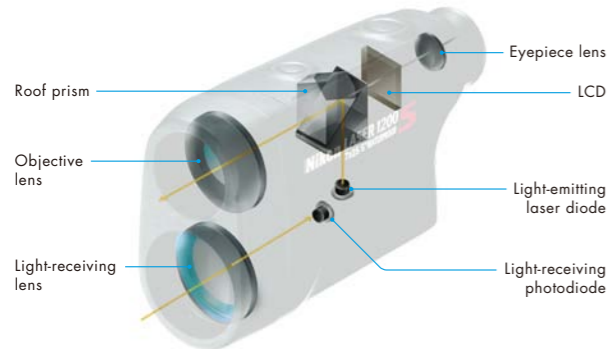

### HYPER READ: Quick, consistent measurement response

Nikon's original data processing algorithm, "HYPER READ", displays the distance measurement result with a fast and stable response, regardless of the distance to the target. This enables you to focus on your game with stress-free measurement.

※ Models that offer HYPER READ:  
COOLSHOT 40i/ COOLSHOT 40/LASER 1000A S/LASER 1200S

### First Target Priority algorithm: Accurate approach

Laser beams are projected and reflected off objects. The First Target Priority algorithm displays the range to the nearest target among the multiple results obtained. You can then exactly measure the distance to the flagstick, instead of a background object. This is especially useful for approach shots.

### Multilayer coating: Increased light transmission

Multilayer coating is applied to the lenses for a much brighter and clearer view. This increases light transmission and reduces flare and ghost due to light reflection. You can thus see just about all target objects on the course with clarity.

### High performance viewfinder: Easy viewing

A large ocular with long eye relief design provides a wide field of view and easy viewing. You can easily catch small targets such as flagsticks.



### Rainproof body design: No worries about sudden rain

The COOLSHOT's body is rain-proof, so you don't have to worry about a sudden shower.

### Ergonomic body design: Easy operation and comfortable handling

The Nikon Laser Rangefinder's body is built compact, lightweight, and optimised for golfing. While maintaining excellent optical performance, COOLSHOT's easy-to-handle ergonomic body design provides comfortable and stress-free operation.



## TARGETING THE FLAGSTICK

In addition to excellent measurement performance, continuous measurement function enables easier measurement of objects as small as the flagstick on the green. By knowing the correct distance to the flagstick, you can improve your approach shot.

### Accurate measurement of distant flagsticks

The premium optical design and sophisticated software employed by COOLSHOT enable accurate measurement of objects as small as a distant flagstick. Hand movement may adversely affect the measurement of the distance to a faraway flagstick. Just use continuous measurement, and you can securely target and measure that distant flagstick.

Guide for maximum measurement distance to a flagstick\*

\*Under Nikon's measurement conditions

**COOLSHOT 40i** Up to approx. 450 yds.

**COOLSHOT 40** Up to approx. 450 yds.

**COOLSHOT 20** Up to approx. 250 yds.

**LASER 1000A S** Up to approx. 380 yds.

**LASER 1200S** Up to approx. 490 yds.

### Continuous measurement minimises hand shake influence

The COOLSHOT'S continuous measurement function minimises the effect of hand shake, enabling easy targeting of a faraway small object like a flagstick. With COOLSHOT 40 or COOLSHOT 20, One-Push Continuous measurement function enables approx. 8-second continuous measurement with a single press of the power button. As for COOLSHOT 40i, LASER 1000A S or LASER 1200S, holding down the power button provides continuous measurement.



### TIPS ON MEASURING DISTANCE TO THE FLAGSTICK



1. Hold the Laser Rangefinder body steady with both hands to prevent hand movement.

When targeting a distant small object like a flagstick, hand movement may influence the result. It is best to hold the COOLSHOT body firmly with both hands.

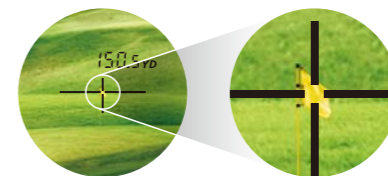

2. Position the flag at the centre of the target mark in the viewfinder.

To measure the distance to the flagstick successfully, target the flag, which is larger than the stick. Position the flag on the centre of the target mark (—+—) in the viewfinder. Note that when your target is off-centre from the target mark, the distance to the object cannot be measured.

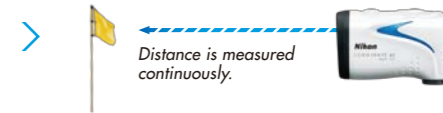

3. Keep targeting the flagstick with continuous measurement.

Continuous measurement function minimises the influence of hand shake or movement. During measurement, the measured distance is displayed consecutively. To obtain distance to the flagstick, keep targeting the flag on the centre of the target mark.

# COURSE TRYOUT

Use the COOLSHOT to effectively measure distance to objects around the fairway and the green, as well as the distance to the exact point where you want the golf ball to land. By knowing the exact distance to your target point with Nikon's laser rangefinder, you can select the proper club to use. Of course, you should also consider wind condition and lie to strategically attack the course.

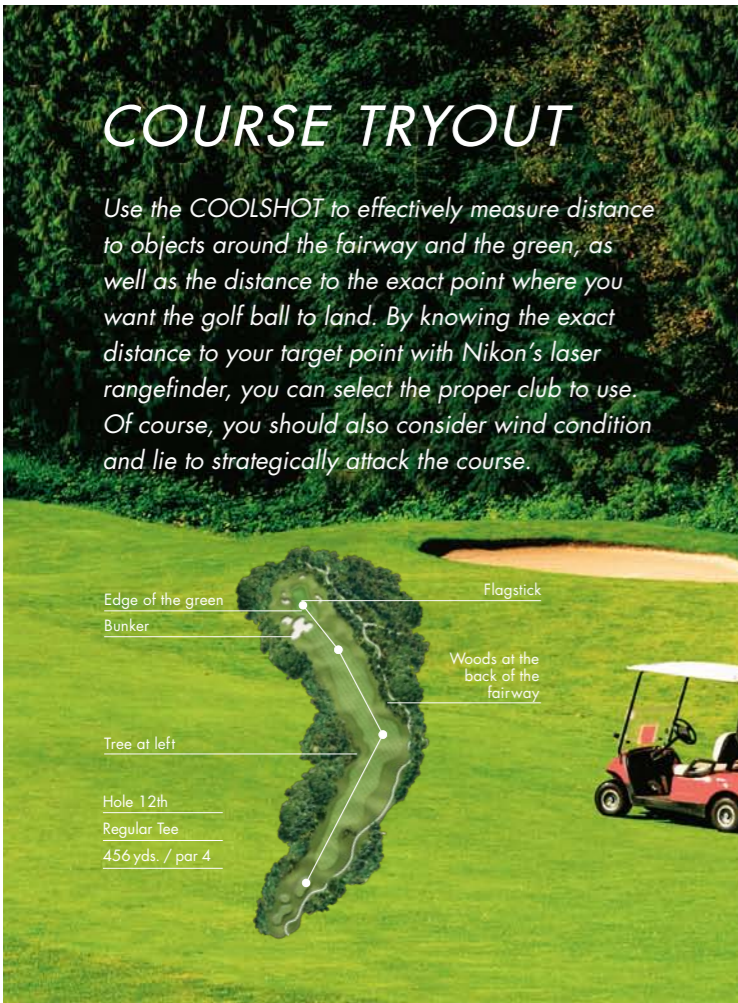

Note: Viewfinder display shown here is a simulated image using the COOLSHOT 40.

## TEE SHOT

Shot with a dogleg corner

A dogleg corner can make estimating distance difficult. In this case, measure the distance to a tree in front of the corner and then the distance to the woods to get the distance to the centre of the fairway. Now you can swing without hesitation.



Note: Viewfinder display shown here is a simulated image using the COOLSHOT 40.

## SECOND SHOT

Shot with a hazard

With a bunker or pond in front of the green, measure the distance to the edge of the green and the distance to the hazard to play it safe.



Note: Viewfinder display shown here is a simulated image using the COOLSHOT 40.

## APPROACH

Uphill shot

On an uphill slope, you may not reach the green without considering height. In cases like this, use a COOLSHOT that's equipped with ID Technology. ID Technology displays the slope adjusted distance, enabling you to hit an accurate shot to reach the green.

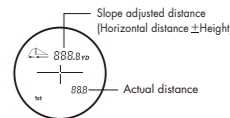

## COOLSHOT 40i

ID Technology which displays slope adjusted distance is provided, along with superior measurement performance.



NEW

## COOLSHOT 40

Designed to measure actual distance with quick response and high accuracy.



NEW

## COOLSHOT 20

The pocket-sized, compact and light model – the smallest and lightest COOLSHOT in the series.



- Measurement range: 7.5-590 m/8-650 yds.
- Golf mode displays slope adjusted distance
- First Target Priority mode is employed; when measuring overlapping subjects, the distance of the closest subject is displayed—useful when measuring the distance to a flagstick on a green with woods in the background
- Target Priority Switch System offers two measurement modes: First Target Priority mode and Distant Target Priority mode
- Single or continuous measurement (up to 8 seconds)
- HYPER READ enables quick and stable measurement response regardless of distance
- Measurement result is displayed in approx. 0.5 seconds
- High-quality 6x monocular with multilayer coating for bright, clear images
- Large ocular for easy viewing (18mm)
- Long eye relief design affords eyeglass wearers easy viewing
- Rainproof — JIS/IEC protection class 4 (IPX4) equivalent (under our testing conditions)
- Compact, lightweight and ergonomic design

### Internal display

- 1 Distance
- 2 Incline
- 3 Decline
- 4 First Target Priority mode
- 5 Distant Target Priority mode
- 6 Unit of measure (m/yd.)
- 7 Laser irradiation (×)
- 8 Target mark (—+—)
- 9 Height (Actual distance at Golf mode setting)
- 10 Battery condition

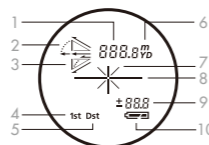

### Display mode cycle



Attention: Use of the COOLSHOT 40i in competitions is prohibited.

- Measurement range: 7.5-590 m/8-650 yds.
- First Target Priority mode is employed; when measuring overlapping subjects, the distance of the closest subject is displayed—useful for measuring the distance to a flagstick on a green with woods in the background
- A single press of the POWER ON/Measurement button provides 8-second continuous measurement, which enables measurement even with slight hand movement
- HYPER READ enables quick and stable measurement response regardless of distance
- Measurement result is displayed in approx. 0.5 seconds
- High-quality 6x monocular with multilayer coating for bright, clear images
- Large ocular for easy viewing (18mm)
- Long eye relief design affords eyeglass wearers easy viewing
- Rainproof — JIS/IEC protection class 4 (IPX4) equivalent (under our testing conditions)
- Compact, lightweight and ergonomic design

### Internal display

1. Distance
2. Unit of measure (m/yd.)
3. Target mark (—+—)
4. Laser irradiation (×)
5. Battery condition

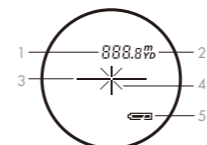

- Measurement range: 5-500 m/6-550 yds.
- First Target Priority mode is employed; when measuring overlapping subjects, the distance of the closest subject is displayed—useful for measuring the distance to a flagstick on a green with woods in the background
- A single press of the POWER ON/Measurement button provides 8-second continuous measurement, which enables measurement even with slight hand movement
- High-quality 6x monocular with multilayer coating for bright, clear images
- Long eye relief design affords eyeglass wearers easy viewing
- Rainproof — JIS/IEC protection class 4 (IPX4) equivalent (under our testing conditions)
- Compact, lightweight (approx. 125g) body

### Internal display

1. Distance
2. Unit of measure (m/yd.)
3. Target mark (—+—)
4. Laser irradiation (×)
5. Battery condition

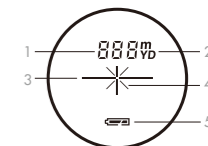



- Measurement range: 10-915 m/11-1,000 yds.
- Golf mode displays slope adjusted distance
- Easy operation enables measurement of actual distance, horizontal distance, height and slope adjusted distance
- Target Priority Switch System offers two measurement modes; First Target Priority mode and Distant Target Priority mode
- Single or continuous measurement (up to 5 seconds)
- HYPER READ enables quick and stable measurement response regardless of distance
- Measurement result is displayed in approx. 0.5 seconds
- High-quality 6x monocular with multilayer coating for bright, clear images
- Wide field of view (7.5 degrees)
- Large ocular for easy viewing (18mm)
- High light transmittance for a brighter field of view
- Long eye relief design affords eyeglass wearers easy viewing
- Waterproof (up to 1m for 10 minutes), but not for underwater usage; the battery chamber is water resistant

Attention: Use of the Laser 1000A S in competitions is prohibited.

#### Internal display

- |                                |   |
|--------------------------------|---|
| 1 Distance                     | 6 Unit of measure (m/yd.)                       |
| 2 Incline ( $\times >$ )       | 7 Laser irradiation ( $\times >$ )              |
| 3 Decline ( $-$ )              | 8 Target mark ( $\text{---}$ )                  |
| 4 First Target Priority mode   | 9 Height (Actual distance at Golf mode setting) |
| 5 Distant Target Priority mode | 10 Battery condition                            |

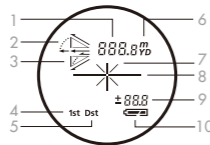

- Measurement range: 10-1,100 m /11-1,200 yds.
- Target Priority Switch System offers two measurement modes; First Target Priority mode and Distant Target Priority mode
- Single or continuous measurement (up to 20 seconds)
- HYPER READ enables quick and stable measurement response regardless of distance
- Measurement result is displayed in approx. 0.5 seconds
- High-quality 7x monocular with multilayer coating for bright, clear images
- Long eye relief design affords eyeglass wearers easy viewing
- Easy one-push measurement after the power is turned on
- Waterproof (up to 2m for 5 minutes), but not for underwater usage; the battery chamber is water resistant

#### Internal display

- |                                |                                    |
|--------------------------------|------------------------------------|
| 1 Distance                     | 4 Laser irradiation ( $\times >$ ) |
| 2 Unit of measure (m/yd.)      | 5 First Target Priority mode       |
| 3 Target mark ( $\text{---}$ ) | 6 Battery condition                |

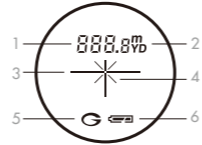

#### SPECIFICATIONS

	COOLSHOT 40i	COOLSHOT 40	COOLSHOT 20	LASER 1000A S	LASER 1200 S
Measurement range	7.5-590m/8-650yds.	7.5-590m/8-650yds.	5-500m/6-550yds.	10-915m/11-1,000yds.	10-1,100m/11-1,200yds.
Measuring accuracy *1 (actual distance)	±0.75m/yd.	±0.75m/yd.	±1m/yd. (shorter than 100m/yds.) ±2m/yds. (100m/yds. and over)	±1.25m/yds.	±1m/yd. (shorter than 300m/yds.) ±0.5% (300m/yds. and over)
ID Technology	✓	—	—	✓	—
HYPER READ	✓	✓	—	✓	✓
Continuous Measurement	One-Push	—	✓	—	—
	Holding down the Power button	✓	—	—	✓
Distance display : Increment	Actual Distance displayed in the upper part: every 0.5m/yd. Actual Distance displayed in the right bottom part: every 1m/yd. Horizontal Distance displayed in the upper part: every 0.2m/yd. Height displayed in the right bottom part: every ±0.2m/yd. (shorter than ±100m/yds.) every ±1m/yd. (±100m/yds. and over)	Every 0.5m/yd.	Every 1m/yd.	Actual Distance displayed in the upper part: every 0.5m/yd. (shorter than 1,000m/yds.) every 1m/yd. (1,000m/yds. and over) Actual Distance displayed in the right bottom part: every 1m/yd. (shorter than 1,000m/yds.) Horizontal Distance displayed in the upper part: every 0.2m/yd. (shorter than 1,000m/yds.) every 1m/yd. (1,000m/yds. and over) Height displayed in the right bottom part: every ±0.2m/yd. (shorter than ±100m/yds.) every ±1m/yd. (±100-999m/yds.) Slope adjusted distance (Horizontal distance ± Height) displayed in the upper part: every 1m/yd. (1,000m/yds. and over)	Every 0.5m/yd. (shorter than 1,000m/yds.) Every 1m/yd. (1,000m/yds. and over)
	Slope adjusted distance (Horizontal distance ± Height) displayed in the upper part: every 0.2m/yd. (shorter than 1,000m/yds.) every 1m/yd. (1,000m/yds. and over)				
Finder	Magnification (x)	6	6	6	7
	Effective objective diameter (mm)	21	21	20	21
	Actual field of view (°)	7.5	7.5	6.0	7.5
	Exit pupil (mm)	3.5	3.5	3.3	3.5
	Eye relief (mm)	18.3	18.3	16.7	18.3
Dimensions (LxHxW) (mm)	112x70x36	112x70x36	91x73x37	118x73x41	145x82x47
Weight (g) (excluding battery)	160	160	125	195	280
Power source	CR2 lithium battery x 1 (DC 3V) Auto power shutoff function equipped (after 8 sec.)				
Structure	Rainproof *2			Waterproof *3	Waterproof *4
EMC	FCC Part15 SubpartB class B, EU: EMC directive, AS/NZS, VCCI class B, CU TR 020				
Safety	IEC60825-1: Class 1M/Laser Product		FDA/21 CFR Part 1040.10: Class I Laser Product	IEC60825-1: Class 1M/Laser Product	
Environment	RoHS, WEEE				

The specifications of these products may not be achieved depending on the target object's shape, surface texture and nature, and/or weather conditions. \*1 Under Nikon's measurement conditions. \*2 Rainproof — JIS/IEC protection class 4 (IPX4) equivalent (under our testing conditions) \*3 Waterproof (up to 1m for 10 minutes), but not for underwater usage; the battery chamber is water resistant \*4 Waterproof (up to 2m for 5 minutes), but not for underwater usage; the battery chamber is water resistant \*Note: The technology behind the Laser Rangefinder with inclinometer originated from technology incorporated in Nikon's Total Station DTM-1 surveying instrument. The Total Station DTM-1, first sold in 1985, was the first highly advanced electronic model of those surveying instruments that incorporated a distance and angle measuring capability developed by Nikon Corporation.